

OPERATION THEORY

EE122 Electro-Mechanical Level Measuring System (nickname "Yo-Yo") is applied to detect the continuous measurement of level heights or filling quantities in bunker plants, silos or tanks. This system is consisted of two parts, the Ee102 Plumb Probe and EE020 Silo Monitoring Controller. The plumb probe is lowered into the silo at an optimal speed by the electric motor control system, when it contacts the material surface, the silo monitoring controller will reverse the direction of the motor thus the plumb probe returns to its starting position, and transmits the distance value. The length of unreel stainless wire serves to calculate the level of the vessel.

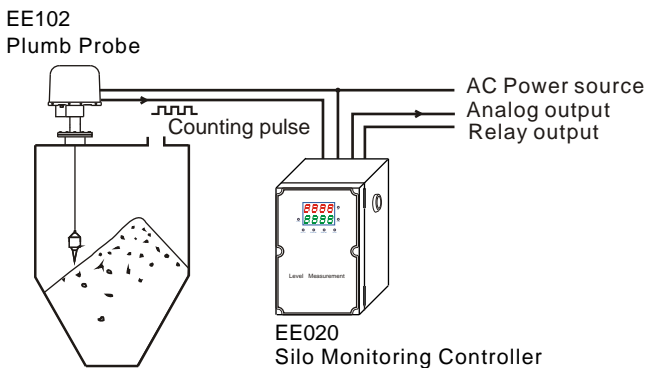

THE MAIN CHARACTERS

- Microprocessor base performance, high efficient output the read value
- 2 set alarm performance relay specified by SPDT , 3A / 250 Vac
- 1 set of 4-20 mA analog signal output
- Two LED display rank (read out value) can indicate the level position or the percentage of the material in the silo, the upper display indicate the Volume percentage or Ratio value defined by Ton , Liter, and lower display is to show the height (distance) of the practical material level in the silo by Meter, Inch, Feet.
- Cable broken alarm : if the plumb cable (wire) broken, the transducer will drive motor stop running and output the readout value on the controller.
- Plumb bob covered alarm : if the sensing plumb bob and its cable (wire) were covered by incoming material, the controller will output the read out value automatically.
- Manual or automatic starting mode selection LED display value can be set to show the real storage or remaining capacity of silo
- The sensing weight will be pulled back at the preset zero point(silo bottom), to avoid the sensing weight slide into silo outlet and cause equipment damage.

APPLICATION

It is applicable to monitor the level of powders, fine grained bulk goods, coarse bulk goods, and liquids

- Suitable for very difficult , heavy dust condition (Silo) tank environment
- Simple and safe measuring principle through a plumb bob.
- Large variety of different type of sensing weight
- Applicable up to measurement range 45m
- Special designs with range up to 70m is available

SPECIFICATION

EE122 Electromechanical Level Measuring System (yo-yo)

EE102 Plumb Probe

EE020 Silo Monitoring Controller

Model: Plumb Probe

- Motor: 40W 220Vac
- Connection: 3/4"NPT
- Resolution: 5cm/pulse, 1"/pulse
- Working temp: -10~80°C
- Air inlet: 1/4"PT
- Air pressure: 1 kg/cm²
- Component material:
- Steel cable--- SUS304 (ϕ 1.2mm)
- Upper cover--- F.R.P.
- Body--- Aluminum
- Flange: 4"x10kg/cm²
- Measuring range: 2~45M
- Weight: approximate 24kg

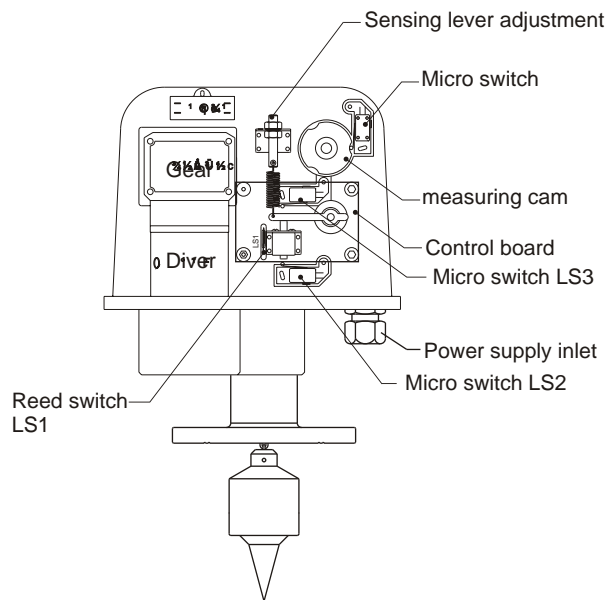
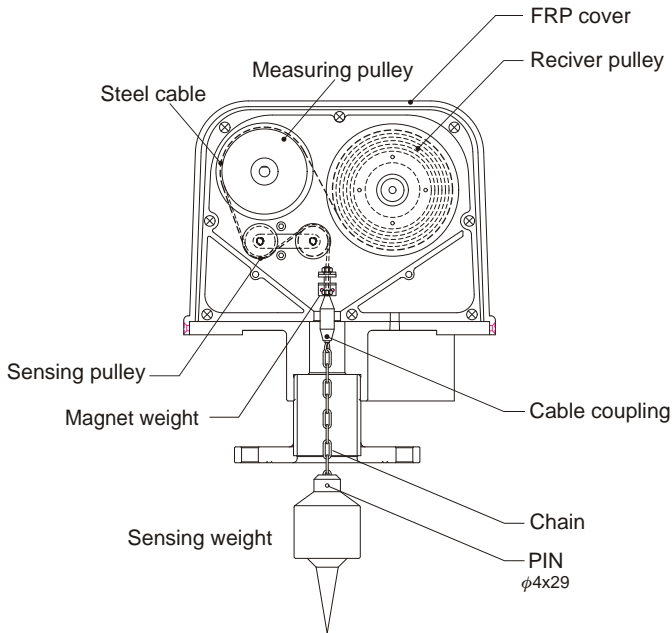
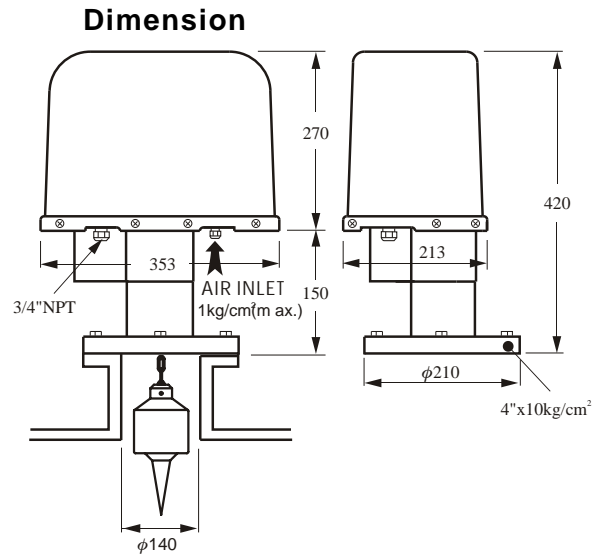

Model: EE020 Silo Monitoring Controller

Power: 220Vac \pm 15%, 50/60Hz (110Vac optional)
 Consumption: 6VA
 Display: upper/lower display, range 0~9999
 Indicator: 2 sets alarm, 5 sets function indicators
 Output: 4~20mA (only), please keep loop resistance low than 600 Ω , resolution: \pm 0.3%
 Relay output: 2 SPDT, 3A/250V
 Working temp: 0~55°C
 Protection grade: IP54
 Dimension: 146mmx222mmx75mm
 Mounting hole size: 115.6x205 / ϕ 4.5x4 hold

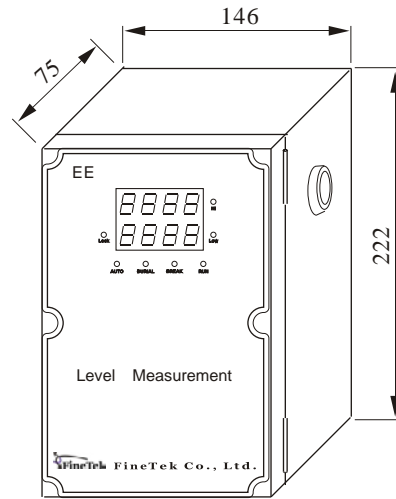

TYPES OF SENSING WEIGHT

Types	Aluminium Alloy	Stainless probe steel	Stainless probe steel
Figure			
Application	General materials	General applications	Light material
Types	Stainless core	Plastic	Stainless probe steel
Figure			
Application	Irregular shape particles	Acid or alkaline materials	Umberlla

※Shape of Sensing Weight can be designed by customer request.

INSTALLATION

Installation site chosen

- Select the installation site away from inlet/outlet of tank to avoid filling product covers the sensing weight or damage the steel cable.
- If there is an inspection window on tank for installation, of course, installation site should closely moving the path for convenient maintenance.
- To avoid sensing weight or steel cable being hook on equipments such as ladder, holder, or protrusile in tank, EE102 installation should keep away from it.

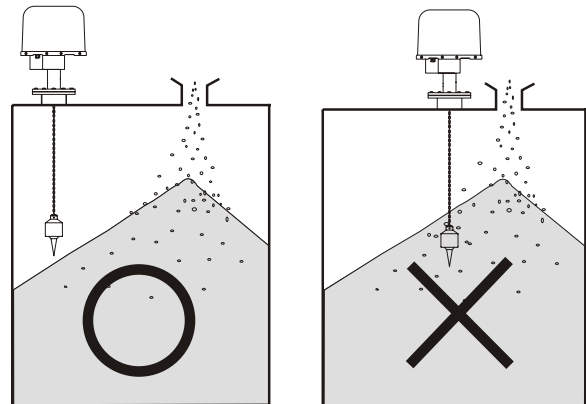

Installation method

- Drilled hole on the tank for EE102 installation has to be wider than 140mm
The flange must be mounted exactly horizontally and the sensing weight and Electromechanical Level Measure must be exactly vertically. It will help to smooth the steel cable moving up and down to avoid the mistake and damage.
- If the roof of the container is not flat, it is necessary to weld a stand pipe to make it horizontal installation. The dimension of pipe has wider than 4 inches also to make its height as short as possible.
- To make two flanges connected closely, a rubber gasket can be put between them.
- If installed in outside surrounding, the cable must went through rubber gasket and screw firmly to avoid liquid flow in.
- Glue must be sealed onto the separated board inside of EE102 to make sure firmly covered and the screws are tightly fixed.
- IF there is NH_3 or other gas inside the container, it is necessary to delivery air simultaneously into "Air inlet" bottom of EE102

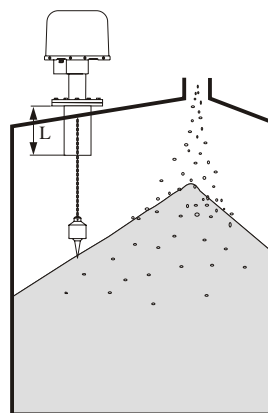
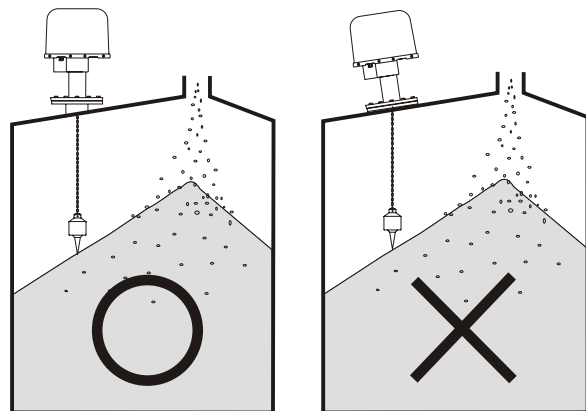

Notice:

- To avoid components damaged, take very carefully while shipment.
- To prevent accident happened in the very beginning of installation, make sure all parts and steel cable are in good condition.

Try to keep installation site away from heavy dust, direct sun light, high emperature and shock.

- ※ Wiring cable: recommend 1.25mm², 8 cords shielding.300M maximum.
- ※ Measuring operation will be stop while the lock switch is short, and "LOCK" light will on. Measuring operation will back to normal while the switch is open, and "LOCK" light will off.

Terminal Arrangement

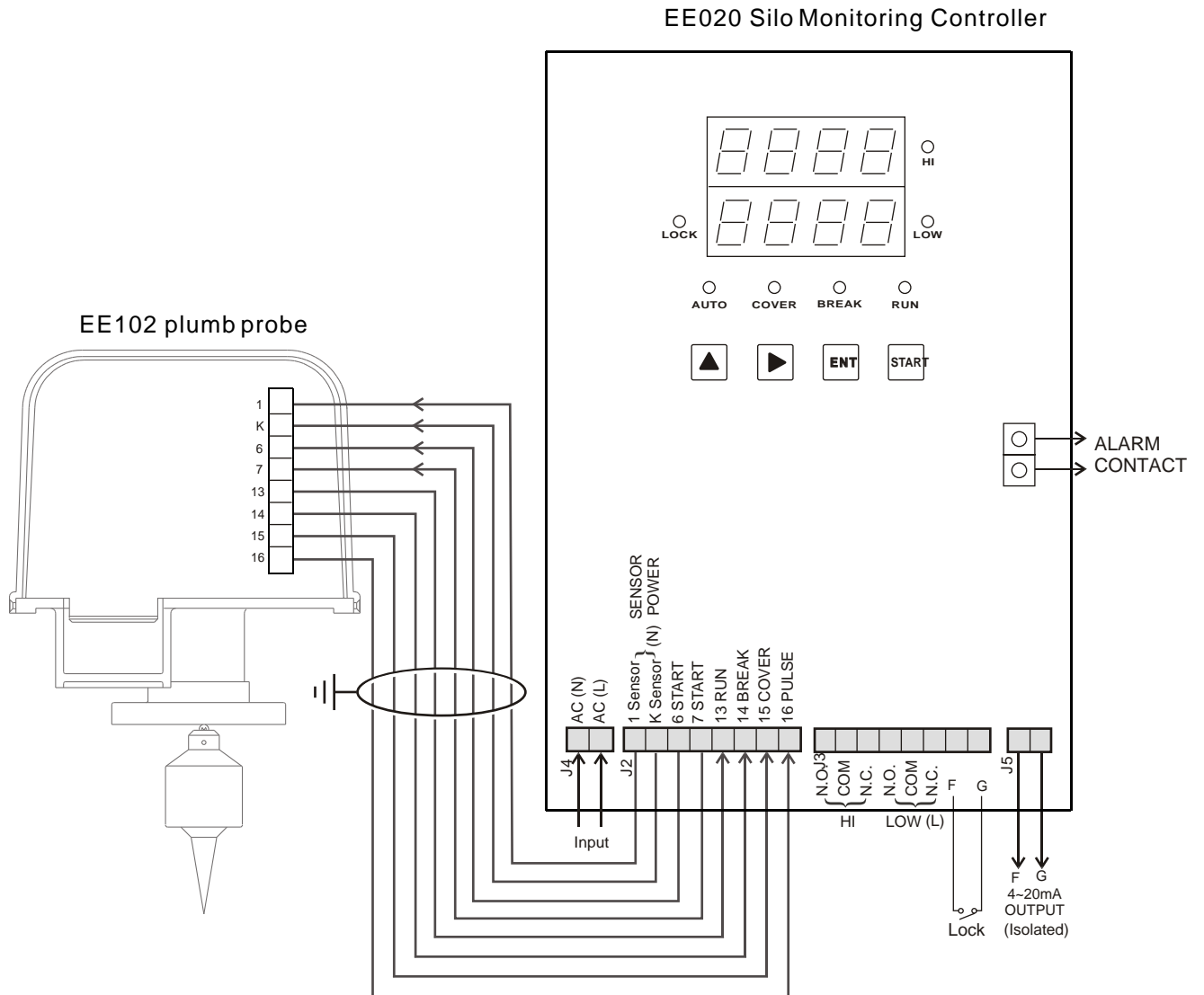

OPERATION PANEL

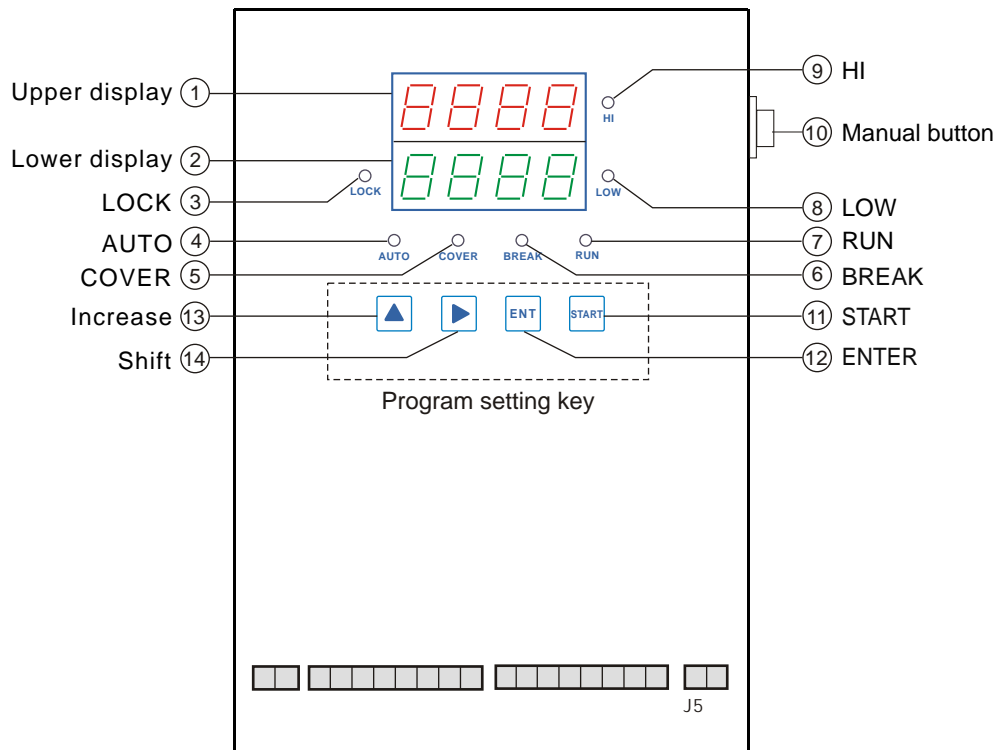

1. **Upper display:** Value represents percentage by means of change scaling parameter. It could be used to display different units proportionally (such as Ton/Liter, etc...)
2. **Lower display:** level position indicator.
3. **LOCK:** When material inflow or equipment maintenance is going on. "Material inflow protect switch" could be connected to short circuit. Measuring process will stop immediately, sensing weight goes back to original position.
4. **AUTO:** Auto light on means it is under automatic detection mode. Light off means in the manual mode. No matter in Auto or Manual modes, press Manual Button (10) can trigger one measuring operation.
5. **COVER:** Cover light on means sensing weight being buried by material. "Err2" shown on display. Measuring value at this time will be ignored. Value shown is previous Measuring one. Meantime, the Analog output (J5 terminal) will send 20mA to Stop material in flow under this situation.
6. **BREAK:** Break light on means Steel cable broken. "Err1" shown on display. Others are the same as "Cover".
7. **RUN:** Run light on means EE102 is detecting level.
8. **LOW:** LOW light on indicates actual level position lower than "low setting position".
9. **HI:** Hi light on indicates actual level position higher than "high setting position".
10. **Manual button:** EE102 runs while Manual button pressed. However, button pressed will have no effect if EE102 is on the process of running stage.

PRODUCT INTRODUCTION

WORKING PRINCIPLE

EE200 series Electro-Mechanical Level Measuring System is consisted of plumb, cable wire, measuring pulley, position sensor, and control board. When measuring, the sensing weight will drop down and cable wire will rotate the measuring pulley. Position sensor and control board will calculate the distance of travel of the sensing weight (medium level) based on how many rotations measuring pulley accomplishes.

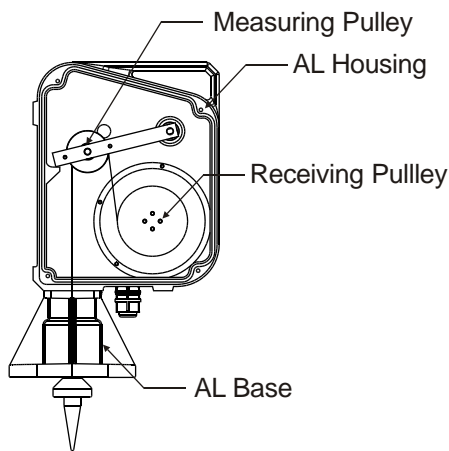

Internal Structure (Rear view)

APPLICATION

- Widely utilized in mining, cement, chemical, and feed industries.
- Suitable for applications of dusty silo, pellet silo, solids silo, liquid silo, unsealed, or vacuum sealed silo.



FEATURES

- Measuring result immune from the interference of environment such as sound waves, dust, capacitance, or temperature change.
- User-friendly with microprocessor-based design.
- High level and low level alarm.
- LCD Dot matrix: 8 x 2.
- Analog output: 4-20mA dc.
- Pulse output: Transistor output(NPN/PNP), Relay output(3A/250Vac)
- Cable Break Alarm: System will detect cable broken during measuring.
- Plumb Buried Alarm: System will detect plumb buried by the medium.
- 4 Forms of Start Mode: auto start, manual start, intelligent start, and external start.
- Intelligent Start: Measuring interval is inverse proportional to medium level.
- Auto Return Setup: Prevent sensing weight from sliding into the tank to damage the equipment when tank is empty.
- Material Fill-Up Protection: Reduce the possibility of plumb being buried.
- Measuring range of 30m.
- RS485 communication protocol.
- Various selections of plumb.

SPECIFICATION

No.	Category	Specification		
1	Power Supply	100~240Vac± 10%,50/60 Hz		
2	Transistor Measuring Resolution	± 3pulse(version with10mm/pulse)		
3	Relay Output Measuring Resolution	± 1pulse(version with100mm /pulse)		
4	Measuring Speed	0.23m/s		
5	Analog Output	0/4-20mA		
6	Pulse Output	1. NPN 、 PNP 2. Relay (3A/250Vac)		
7	Display	LCD (Dot matrix , 8 X 2)		
8	Status LED	1.Lock 2.RUN 3.Buried 4.Break 5.Auto 6.High Alarm 7.Low Alarm		
9	Ambient Temperature	-35°C- 60°C		
10	Operating Temperature	-35°C- 80°C		
11	Measuring Range	30m Max		
12	Protection Level	IP66		
13	Relay Output	SPDT 3A/250Vac X 3 (1.HI Alarm 2. LO Alarm 3.Buried 、 Break 、 Lock (Output mode as indicated)		
14	Anti-Dew Heater	Thermostat controlled (16°C)		
15	Cable Break Detection	Yes		
16	Sensing Weight Buried Detection	Yes		
17	Manual/Auto Measuring Mode	Yes(0.1-99h)		
18	Motor Protection	Yes		
19	Malfunction Diagnosis Display	Yes		
20	Material Fill-Up Protection	Yes		
21	Communication Protocol (RS485)	Yes	Frame	C8N1.C8N2.C801.C8E1.C7N2.C701. C7E1.C702. C7E2.C9N1
			Baudrate	1200.2400.4800.9600. 11520. 14400.19200.28800.57600
22	Intelligent Start	Measuring interval is inverse proportional to medium level.		
23	Reset Output	Reset (3A/250Vac)		
24	Cable Wire	1.2mm ^φ		

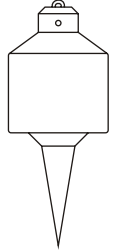
Types of plumb

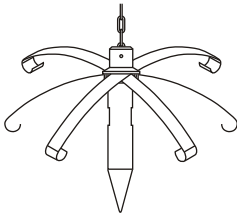
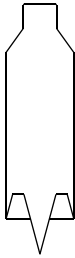
A	B	C	D
Aluminum Alloy	Stainless probe steel float type	Umbrella	Plastic Auto-Fall-Off
			

※ Custom made is available for sensing weight

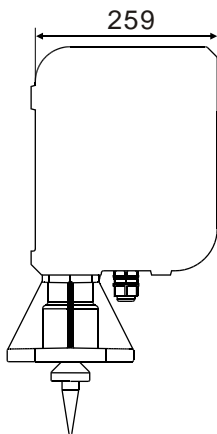
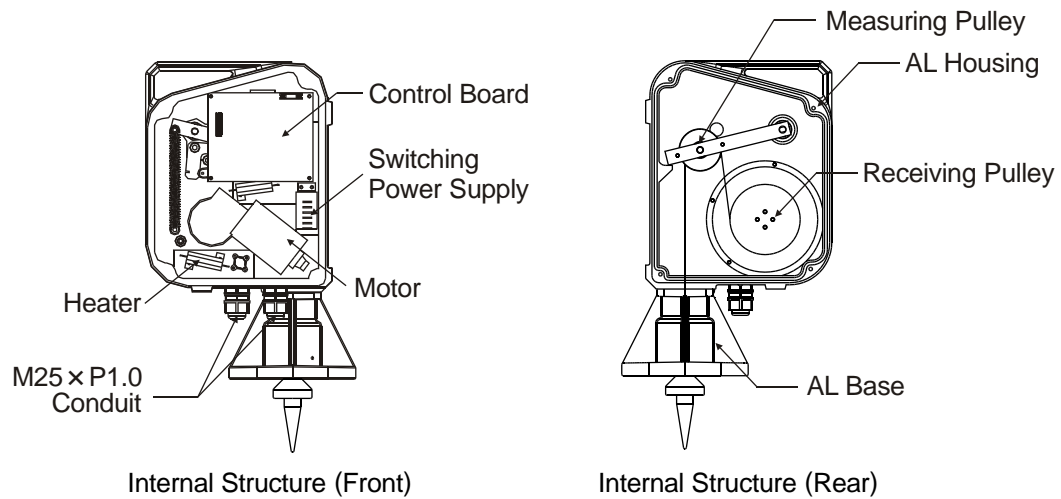

Dimension (Front)

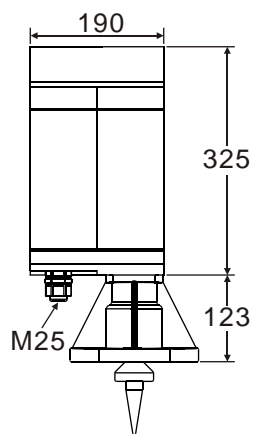

Dimension (Side)

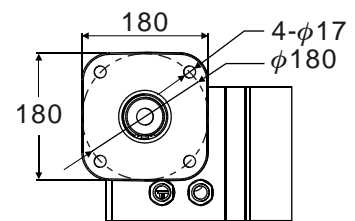

Base Dimension

CONTROL BOARD LAYOUT

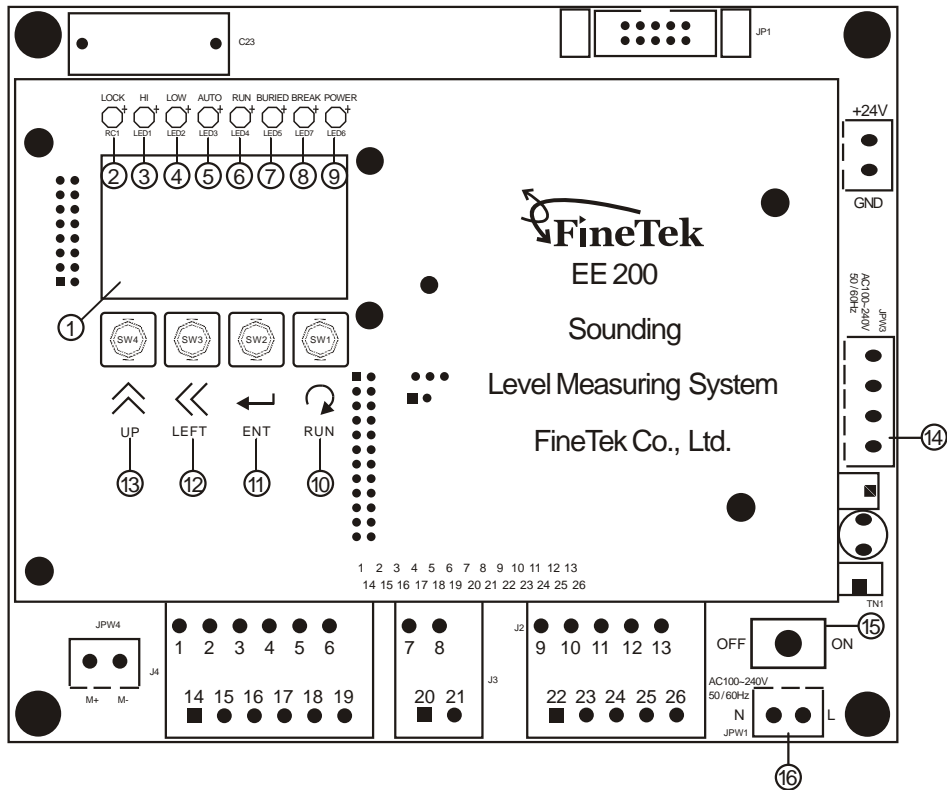

- ① Display
- ② Material Fill-Up Protection Indicator:
- ③ High Level Alarm Indicator: LED is on when medium exceeds high level set point.
- ④ Low Level Alarm Indicator: LED is on when medium is below low level set point.
- ⑤ Auto Start Indicator: LED is on when Auto Start is selected.
- ⑥ Start Indicator: LED is on when measuring and off when measuring ends.
- ⑦ Sensing Weight Buried Indicator: LED blinks for 1 second when plumb is buried. Buried message will be displayed.
- ⑧ Cable Break Indicator: LED blinks for 2 seconds when cable is broken. Break message will be displayed.
- ⑨ Power Indicator
- ⑩ Start Button
- ⑪ Enter Button
- ⑫ Shift Button
- ⑬ Up Button
- ⑭ Heater Output Terminal
- ⑮ Power Switch
- ⑯ Power Terminal (L.N.)100~240Vac.50/60Hz

ORDER INFORMATION



EE200-- -

TEMPERATURE CONTROL

- 0:None
- 1:Yes

CONNECTION

00 : Standard ($\square 180$ PCD180, 4- $\phi 17$)

SENSING WEIGHT TYPE

- A : Aluminum Alloy
- B : Stainless probe steel float type
- C : Umbrella
- D : Plastic Auto-Fall-Off

MEASURING RANGE (m)

- 02:2m(min.)
- 30:30m(max.)