



Extra information for ...Run Valve actuators

for optimization of planning, installation and initial startup for safe operation



Assembly

- ▶ Dimensions, drill plate
- ▶ Control elements: switch – push buttons – LED
- ▶ Outdoor installation
- ▶ Mounting and adaptations



Electric

- ▶ Power supply design
- ▶ Cross sections and line lengths
- ▶ Commissioning, requirements for controller, maintenance
- ▶ Problem treatment/error indication

Subject to change!

▶ Dimensions

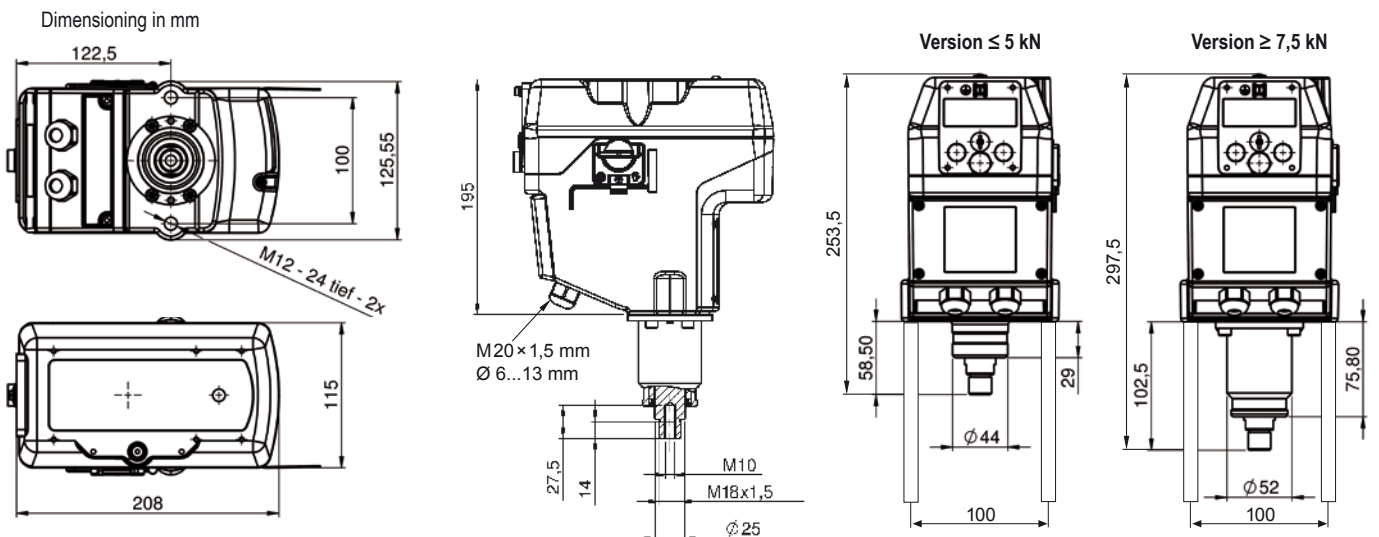

▶ Control elements: switch – push button – LED

All actuators are equipped with a 10-position switch, a push button and a multicolour LED for calibration. These control elements are to be found cable-laterally behind the two middle sectioned dummy plugs. For operation these must be removed. The calibration can be achieved despite lining up power supply at the actuator. The explosion prevention is not impaired thereby. However, it has to be of great concern that the dummy plugs must be rescrewed in order to comply with the IP-protection class.

The operation of the switch and button has to be done by means of a small screwdriver. Force with strong pressure and/or rotation is to be avoided in any case, since otherwise control electronics can be damaged irreparably. Adjustments of force and running time can be achieved also before mounting. The self adjustment of stroke can be started only with an outside load and accurate mounting.

Switch – Push button – Lamp for adjustment (behind the blanking plug)

- 10-position switch (S)
- Push button (T)
- 3-colour LED

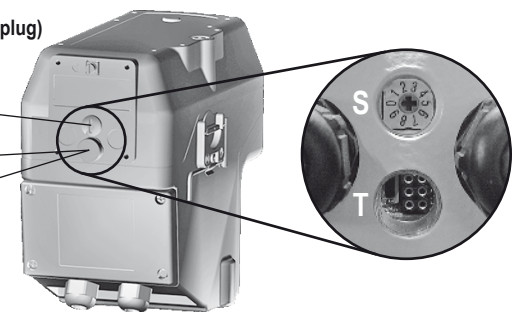

▶ Outdoor installation or at high dust exposure

When mounting actuator outdoors it has to be certain that the actuator is protected against direct sun exposure (heat and UV!), rain and snow by employing an enclosure roof. Supply voltage is to be applied immediately after mounting in order to assure integrated heating at start.

Since explosion proof actuators must have internal safety temperature limiters, these may not be exposed to a too high temperature, neither at storage nor during operation. Otherwise the limiters could respond and switch off the actuator irreversibly.

At high dust exposure appropriate counteraction has to be taken, e.g. mounting a rubber bellow on rod.



► **Mounting of ...Run actuators**



When mounting particularly observe the following:

- The linkage spacer columns for the actuators should only be mounted vertically.
- Valve actuators should only be mounted as shown, never suspended.
- When mounting on a steam valve, the actuator should not be mounted vertically above the valve as the rising heat and steam could cause damage at parts of the actuator.
- If mounted outside or in areas with a high level of humidity, the drive must be equipped with a heater.
- Vibration should be avoided, they shorten the serviceable life of the actuators. Suitable shock absorption should be incorporated.
- Pressure fluctuations in steam systems must be avoided to protect the actuator.

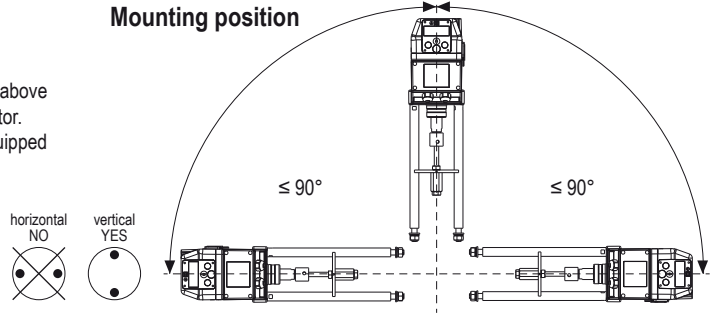

Valve adaption

For mounting and adjustment act as follows:

- The actuator needs a specific linkage to match the selected valve
- The construction of the valve linkage is determined by the used valve
- Check the stroke of actuator and compare with valve if necessary adjust stroke
- Check adaption
- Mount actuator to valve

Stroke setting

The max. stroke is 60 mm. To reduce this turn the adjusting screw. Open the lateral cover of actuator. Remove the 5 screws of the cover and set the adjusting screw of needed stroke. (see ...Run data sheet page 4).

1. The actuator will be delivered with retracted stroke!
2. Place the actuator on the valve body and attach with the nuts and washers provided.
3. Remove the cap nut (2) and screw the connecting parts with the connecting nut (3), taking care not to damage the valve spindle. The spindle should be retracted as far as possible into the valve body.
4. Allow enough distance between the threaded bolt head (4) and the rod of the actuator, **noting the travel of the valve spindle**. Any adjustment can be done by screwing the bolt (4) into the connection nut (3).
5. Screw the nut (5) hand tight. Draw out the valve spindle with the connecting parts until contact is made to the threaded actuator rod and join with the cap nut (2). **Do not overtighten (max. 4 Nm) otherwise damage will be cause to the mounting bracket.**
6. Connect the actuator to the supply in accordance with the wiring diagram.
7. Operate the actuator electrically to fully extend the actuators rod. For modulated controlled actuator with a 4 mA or 0 VDC positioning signal or by connecting to load via terminal 4 (if no positioning signal available). Visual check that the valve is closed. Minor adjustment to the travel can be achieved by turning the threaded bolt (4).
8. Connections: take care not to operate the actuator against the stroke otherwise damage to mounting bracket may occur.
9. Start adjustment drive.
10. The actuator is ready to operate.

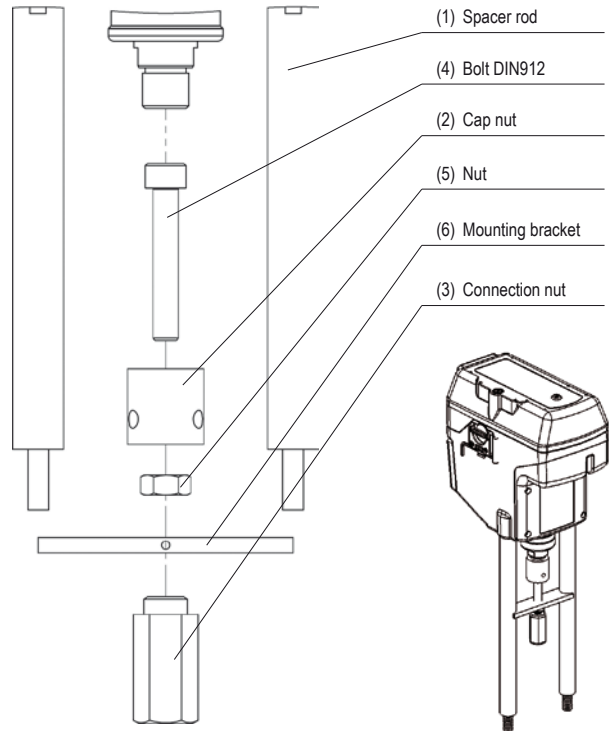

Commissioning on a 2- or 3-way valve

2-way valve

- Use only adaptations suitable for the drive
- Mount adaption to actuator
- Set stroke considering internal and external end positions
- Push button (T) for 3 sek. (necessary for "modulation" Y-types)
- Actuator drives in the adjusted end position and scales the stroke automatically

3-way valve

An adaption on a 3-way valve is checked as above. You only need to take into account that the lift rod must move to both of the valve closures. This can necessitate a repeated check or adjustment.

Fixing the valve stroke into position

With 3-way valves the valve stroke must be less than the actuator's stroke. The valve stroke must be measured exactly so as to eliminate \pm tolerances. The actuator's stroke must be slightly greater than the valve stroke (3-way valves close in two directions). For 2-way valves it is possible to use the value stated in the written information. However, many valve manufacturers do not allow travel beyond its fully opened/closed position (2-way valves only close in one direction).



► Power input depending of supply voltage

The design of the on-site supply depends on the selected motor running time and selected supply voltage. Accompanying values are "about values" since there can be construction unit dispersions within electronics. The power consumption in the blocking position is run time independently at approx. 5 W. The power consumption for the heater is approx. 16 W. The heater switches on only when motor is in idle position!
The initial starting supply voltage required by the actuators power supply unit is approx. 2.0 A. The starting pulse takes about 1 sec. (Please consider this while conceiving the cross section of the supply line). The power factor is between 0.8 and 0.5 in dependence of motor running time. A line protection should be with min. 2 AT.

- Power connection must be made with switched off circuits, always!
- Do not open the junction box when circuits are live
- Note supply voltage!
Wrong connection or over voltage are not covered by warranty
- The cable of the actuator must be installed in a fixed position and protected against mechanical and thermal damage
- Electrical connection with integral terminals only
- Electrical connection with integrated junction box. After this close all openings and thighten screws
- Inrush current is approx. 2 A up to 1 sec. (please note for dimensioning)
- The cross section of the wiring please choose according the length of the wiring and the necessary power consumption of the actuator. Too small cross sections are very often the reason for malfunctions

Load		Rated current in acc. with motor running time									
		500 N					1000 N				
Voltage	Current	2 s	3 s	6 s	9 s	12 s	2 s	3 s	6 s	9 s	12 s
24 VDC	I _{Nominal} [A]	0,5	0,4	0,3	0,4	0,3	1,0	0,8	0,6	0,5	0,5
120 VAC	I _{Nominal} [A]	0,4	0,3	0,2	0,1	0,1	0,4	0,3	0,2	0,1	0,1
240 VAC	I _{Nominal} [A]	0,3	0,2	0,1	0,1	0,1	0,3	0,2	0,1	0,1	0,1

Load		Rated current in acc. with motor running time									
		2500 N					5000 N				
Voltage	Current	2 s	3 s	6 s	9 s	12 s	2 s	3 s	6 s	9 s	12 s
24 VDC	I _{Nominal} [A]	0,6	0,5	0,3	0,3	0,3	0,9	0,6	0,4	0,3	0,3
120 VAC	I _{Nominal} [A]	0,4	0,3	0,2	0,1	0,1	0,5	0,4	0,4	0,3	0,3
240 VAC	I _{Nominal} [A]	0,3	0,2	0,1	0,1	0,1	0,3	0,2	0,1	0,1	0,1

Load		Rated current in acc. with motor running time									
		7500 N					10.000 N				
Voltage	Current	4 s	6 s	9 s	12 s	15 s	4 s	6 s	9 s	12 s	15 s
24 VDC	I _{Nominal} [A]	1,2	1,0	0,8	0,6	0,4	1,5	1,2	1,0	0,7	0,5
120 VAC	I _{Nominal} [A]	0,5	0,5	0,4	0,3	0,3	0,5	0,4	0,4	0,4	0,3
240 VAC	I _{Nominal} [A]	0,5	0,5	0,4	0,4	0,3	0,6	0,5	0,4	0,4	0,2

► Dimensioning cross sections and line lengths

On long distances between voltage supply and drive, voltage drops occur due to line resistances. As a consequence with 24 VAC/DC the actuator receives a too low tension and does not start. In order to prevent this the cross section of the inlet line is to be dimensioned accordingly.
The accompanying formulas allow the calculation of the necessary line cross section respectively maximal permitted conduit length respectively utilizing the existing line cross section.
Alternatively the secondary voltage can be increased by selecting a transformer.

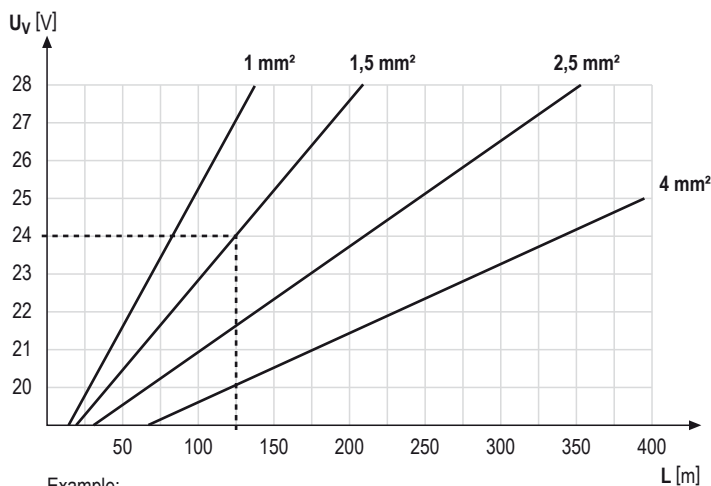

Example:
24 V power supply with wire diameter 1,5 mm² = cable length 126 m

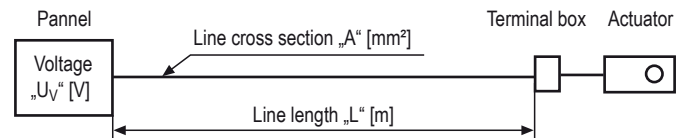

Required cable cross section A at existing cable length L

$$A = 0,0714 \times L : (U_V - 18 V)$$

Example: L = 250 m, U_V = 30 V
Cross section A = 1,5 mm²

Maximum cable length L at existing cross section A

$$L = A \times (U_V - 18 V) : 0,0714$$

Example: A = 1,5 mm², U_V = 24 V
Length of cable L = 126 m

For calculation following characteristics are essential:

- U_V = supply voltage [V]
- A = line cross section [mm²]
- L = conduit length [m]
- Factor 0,0714 = drive specific factor [Vmm²/m]
(based on the electrical conductivity of electrolytic copper with a coefficient of 56 m/Ωmm²)



► Commissioning / Operation

Check before turning on

- Ensure that the supply voltage is in accordance with the specifications
- Connect protection earth and potential equalisation
- The actuator must not display any type of mechanical damage

Commissioning and function control

- Check the wiring and control function
- Rod goes in – with contact 2 to 3
- Rod goes out – with contact 2 to 4
- Check manual override

With manual override the rod has to be moved very carefully in the end positions. Actuator and valve could be damaged.

Check options

- Check internal aux. switches regarding end position
- Check feedback potentiometer
- Adjust external switches

Further checks

- Check valve and actuator linkage to confirm correct connection
- Check the terminal box for damage

Before switching off, consider the effects on the system and on other devices. Disconnect the mains before starting mechanical dismantling. The junction box must be free of voltage. Loosen the linkage and remove the actuator.

► Requirements for controller

The controller must ensure that the following conditions are fulfilled:
To ensure a high accuracy and long life actuators are equipped with "protective mechanisms". They protect all electric motors against early wear.
For 2- and 3-position actuators, a minimum control time of 0.5 second must be attained. If the controller pulses in shorter steps (< 0.5 s), the actuator will not respond. The time between the impulses must be min. 0.5 s.
Note: At small control deviations the actuator is permanently active. This can arise over-temperature and the actuator goes in STOP position. This self protection is evidence that the control loop is incorrect.
Schischek recommends using Y-actuators for control applications.

► Maintenance

Relating to operation actuators are maintenance free. Nevertheless maintenance must comply with regional standards, rules and regulations. The actuator should be opened for adjustments only. After setting all covers must be closed.
Damaged junction boxes, cable glands or gaskets must be exchanged for original parts or sent for repair to Schischek GmbH.

► Problem handling / Error indication

Problem	Possible cause	Course of action
01 Actuator does not work LED does not light	<ul style="list-style-type: none"> • No power supply attached • The actuator is operated at ambient temperature beyond specifications and the internal temperature sensor shut down irreversibly 	<ul style="list-style-type: none"> • Attach power supply and turn on • Caused by inadmissible operation and for safety relevant reasons the actuator drove into an irreversible condition and must be exchanged. Accompanying new installation the ambient temperature has to be reduced accordingly
02 Actuator does not work LED lights RED	<ul style="list-style-type: none"> • The actuator is operated at a too high ambient temperature and the internal temperature sensor responded 	<ul style="list-style-type: none"> • Shut off actuator and let temperature decrease, reduce ambient temperature by suitable measures e.g. ventilation or other mounting position of the actuator
03 Actuator does not work LED lights GREEN	<ul style="list-style-type: none"> • 3-pos. control signal is wired on both entrances • Required torque is greater than actuators torque • Control signals are not attached or attached on a wrong conductor • Actuator is incorrectly mounted and is blocked by an external stop unit • Actuator is clogged with impulses < 0,5 s and therefore ignored the signals • Interchanged supply lines 	<ul style="list-style-type: none"> • Readjust / correct circuit • Adjust a higher torque at the actuator if possible otherwise exchange for a type with higher torque • Examine rule and adjusting signals and connect in accordance with diagram • Dismount actuator and testdrive without load for operability. Then install actuator accordingly so that the power transmission of the actuator runs the armature/damper without external blockade or torsion • Switch off supply voltage for at least 2 s. Thereby a reset is conducted. Readjust the controller in order to extend control pulses • Switch wires: 1 must be connected to (-, N) and wire 2 to (+, L)
04 Actuator does not work LED is blinking RED	<ul style="list-style-type: none"> • The actuator has been mounted at temperatures < -20 °C and did not reach its operating temperature of at least -20 °C 	<ul style="list-style-type: none"> • Ensure that a constant voltage supply is applied on conductor 1–2 • Wait until the required operating temperature is achieved by the actuators internal heating system. The actuator will start operating independently
05 LED flashes irregularly, actuator does not work	<ul style="list-style-type: none"> • Actuator does not receive sufficient supply voltage • Cable to long, voltage drop in the supply line too large 	<ul style="list-style-type: none"> • Increase line cross section or power supply at output of the transformer • Increase line cross section or power supply
06 LED briefly flashes RED, end position is not reached	<ul style="list-style-type: none"> • Actuator is in blocking position 1 × blinking: block position, rod goes in 2 × blinking: block position, rod goes out 	<ul style="list-style-type: none"> • External load is higher than actuator's max. force. Check mechanic for easy movement and tensioning, eventually for test purposes without valve