Users guide MG-XC

Counter 4- to 8-digit



- **Panel instrument type MG-BC**
- **Construction instrument type MG-AC**

Contents

1.	Brief description.....	3
2.	Safety instructions.....	3
2.1.	Proper use.....	3
2.2.	Control of the device.....	3
2.3.	Installation.....	3
2.4.	Notes on installation.....	3
3.	Assembly.....	4
3.1.	Panel instrument MG-BC.....	4
3.2.	Construction instrument MG-AC (57mm and 100 mm display height).....	5
4.	Electrical connection.....	6
4.1.	Connection position for pulse counter MG-AC built-on enclosure.....	6
4.2.	Connection position for pulse counter MG-AC panel enclosure.....	6
4.3.	Connection examples for MG-AC.....	7
5.	Operating and display elements.....	8
6.	Programming.....	9
6.1.	Programming procedure.....	9
7.	Software.....	11
7.1.	Range of functions.....	11
7.2.	Switching on.....	11
7.3.	Help.....	11
7.4.	Overflow.....	11
7.5.	Underflow.....	11
7.6.	Forward / backward counter.....	11
7.7.	Pre-scaler function 1/1000.....	12
8.	Program table.....	13
8.1.	pnp/npn logics PN1.....	14
8.2.	Mode of operation of the counter PN2.....	14
8.3.	Pre-scaler function PN3.....	14
8.4.	Pre-scaler factor PN4.....	15
8.5.	Decimal point PN5.....	15
8.6.	Reset mode PN6.....	15
8.7.	Reset treatment PN7.....	15
8.8.	Starting value PN8.....	15
8.9.	Counting direction PN9.....	15
8.10.	Limit value for counter reset PN10.....	15
8.11.	Authorization code PN50.....	15
8.12.	Preset authorization code PN51.....	15
8.13.	Limit value function of the set points PN60/70.....	16
8.14.	Limit value threshold of the set points PN61/71.....	16
8.15.	Drop out time of the set points PN62/72.....	16
8.16.	Mode of operation of the set points PN63/73.....	16
9.	Technical data.....	17
10.	Memos.....	20

Brief description

1. Brief description

The **MG-XC** display is driven by pulses or a programmable time base, and shows a value proportionate to this on the 7-segment display. The display has two set points that can be set to freely parameterisable limit values. *Chapter 7.1* contains an overview of the functions.

2. Safety instructions

Please read the users guide before installation and keep it for future reference.

2.1. Proper use

The **MG-XC** is determined for recording of impulses and its display.



Danger! Careless use or improper operation can result in personal injury and/or damage to the equipment.

2.2. Control of the device

The devices are checked before dispatch and sent out in perfect condition. Should there be any visible damage, we recommend close examination of the packaging. Please inform the supplier immediately of any damage.

2.3. Installation

The **MG-XC** must be installed by a suitably qualified specialist (e.g. with a qualification in industrial electronics) or somebody with comparable qualifications.

2.4. Notes on installation

- There must be no magnetic or electric fields in the vicinity of the device, e.g. due to transformers, mobile phones or electrostatic discharge.¹
- The fuse rating of the supply voltage should not exceed a value of 6A N.B. fuse.
- Do not install inductive consumers (relays, solenoid valves etc.) near the device and suppress any interference with the aid of RC spark extinguishing combinations or free-wheeling diodes.
- Keep input, output and supply lines separate from one another and do not lay them parallel with each other. Position go and return lines next to one another. Where possible use twisted pair.
- The device is not suitable for installation in areas where there is a risk of explosion.
- Any electrical connection deviating from the connection diagram can endanger human life and/or can destroy the equipment.
- The unit must not be mounted in the vicinity of direct sunlight.
- Do not install several devices immediately above one another (see ambient temperature).¹

¹ see technical data

Assembly

3. Assembly

The **MG-XC** is intended for installation in a control panel or as constructive instrument (please state version by order).

3.1. Panel instrument **MG-BC**

Before assembly, a cut-out must be made to accommodate the device. The sizes and tolerances are given in the technical data. The device should be installed with the supplied fixtures in line with the drawings.

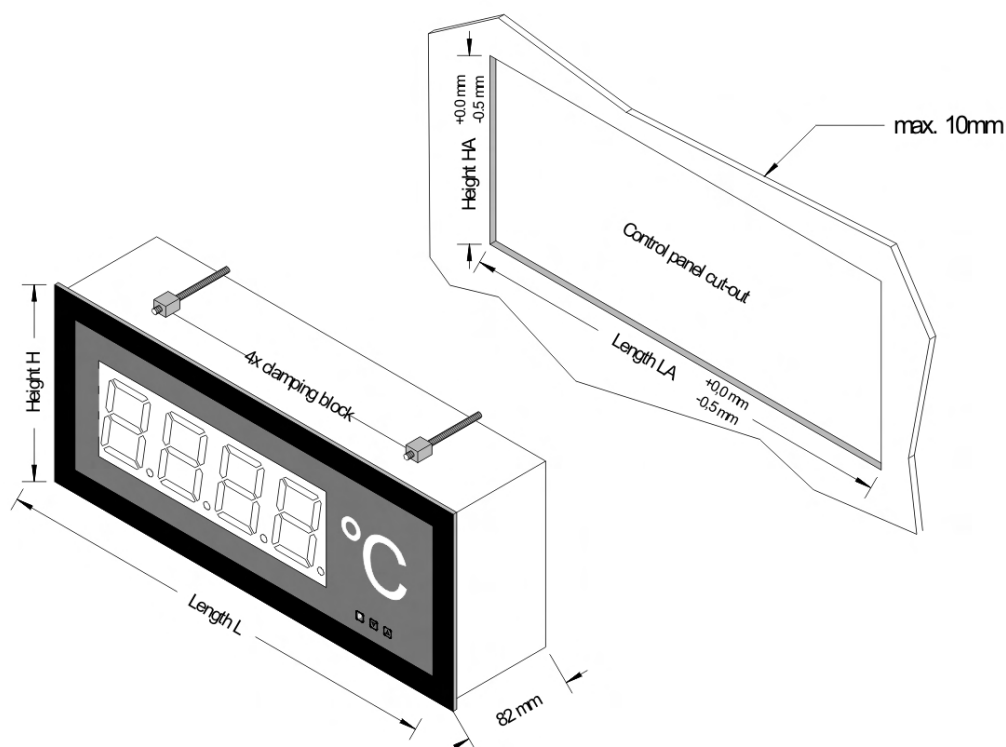

Display 57 mm

Version A

Number of digits	Length L	Length LA	Height H	Height HA
3-digit with physc. value	288mm	282mm	144mm	138mm
4-digit with physc. value	336mm	330mm		
5-digit with physc. value	384mm	378mm		
6-digit with physc. value	432mm	426mm		
7-digit with physc. value	480mm	474mm		

Version B

Number of digits	Length L	Length LA	Height H	Height HA
3-digit with physc. value	268mm	262mm	124mm	118mm
4-digit with physc. value	316mm	310mm		
5-digit with physc. value	364mm	358mm		
6-digit with physc. value	412mm	406mm		
7-digit with physc. value	460mm	454mm		

Display 100 mm

Version A

Number of digits	Length L	Length LA	Height H	Height HA
3-digit with physc. value	460mm	454mm	200mm	194mm
4-digit with physc. value	550mm	544mm		
5-digit with physc. value	640mm	634mm		
6-digit with physc. value	730mm	724mm		
7-digit with physc. value	820mm	814mm		

Version B

Number of digits	Länge L	Länge LA	Höhe H	Höhe HA
3-digit with physc. value	436mm	430mm	176mm	170mm
4-digit with physc. value	526mm	520mm		
5-digit with physc. value	616mm	610mm		
6-digit with physc. value	706mm	700mm		
7-digit with physc. value	796mm	790mm		

Assembly

3.2. Construction instrument **MG-AC** (57mm and 100 mm display height)

For fixing of the device, please use the assembly drillings in the fastening angle.

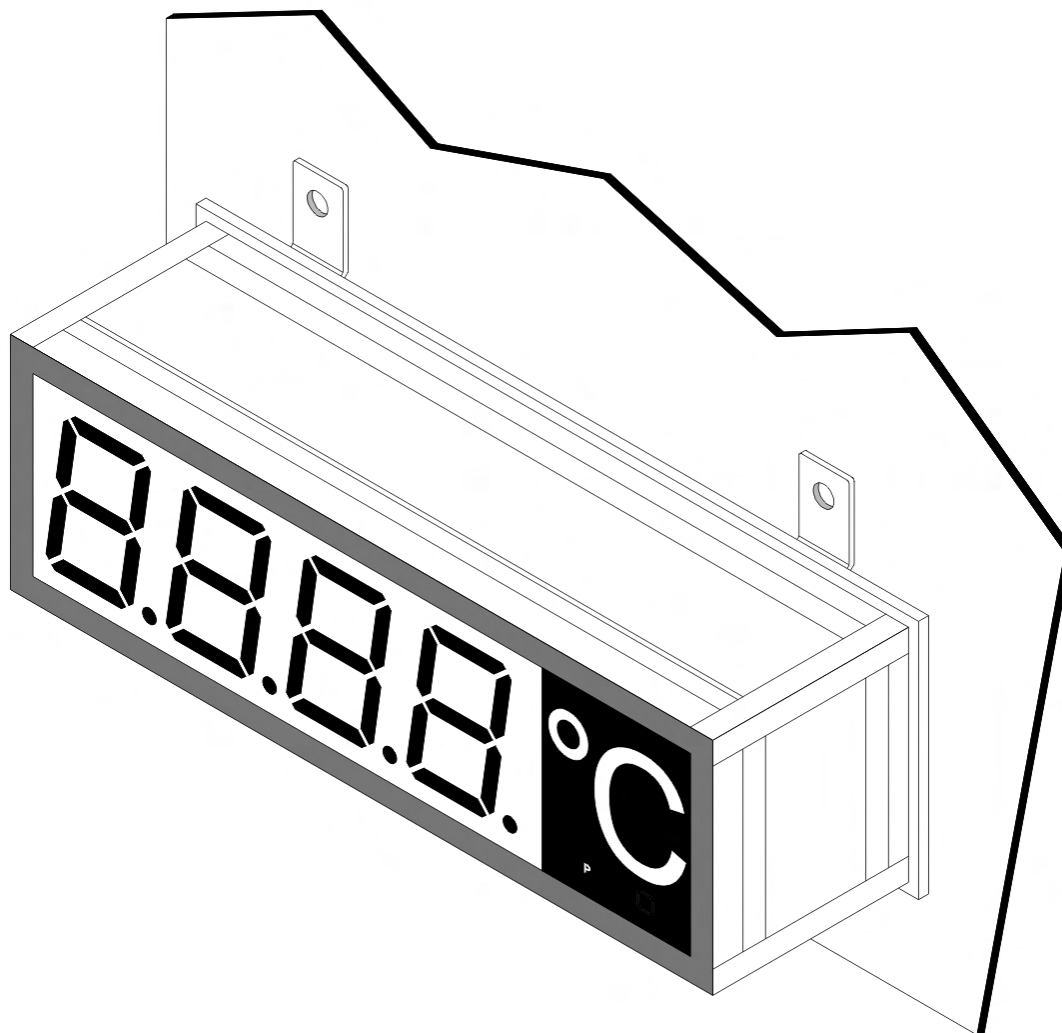

Electrical connection

4. Electrical connection

The electrical connection is made on the rear or the top of the unit. The electrical connection will depend on which version has been ordered. All the possible connections for the **MG-XC** are described below.

4.1. Connection position for pulse counter **MG-AC** built-on enclosure

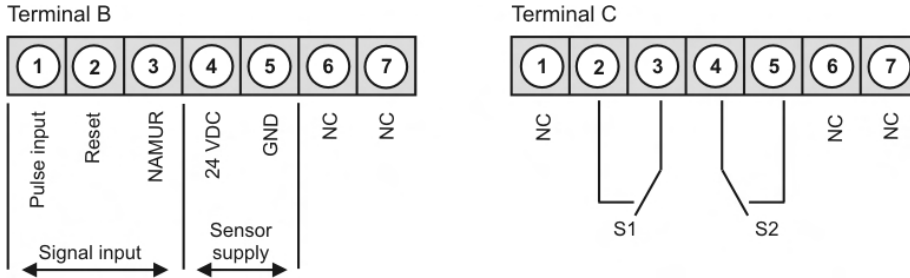

Connection pattern voltage supply

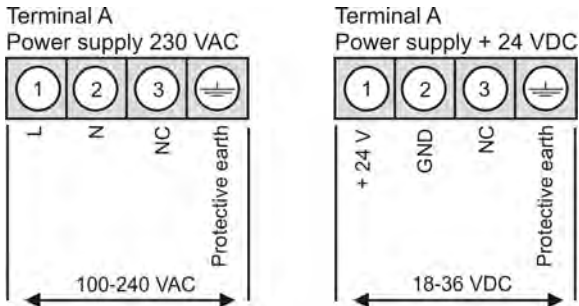

Location of the connection terminals (**MG-AC**)

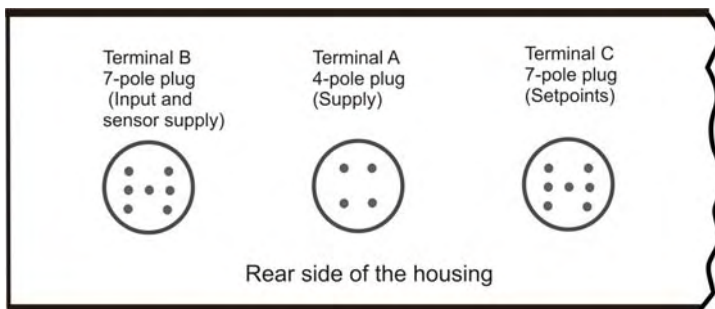

4.2. Connection pattern for pulse counter MG-BC panel enclosure

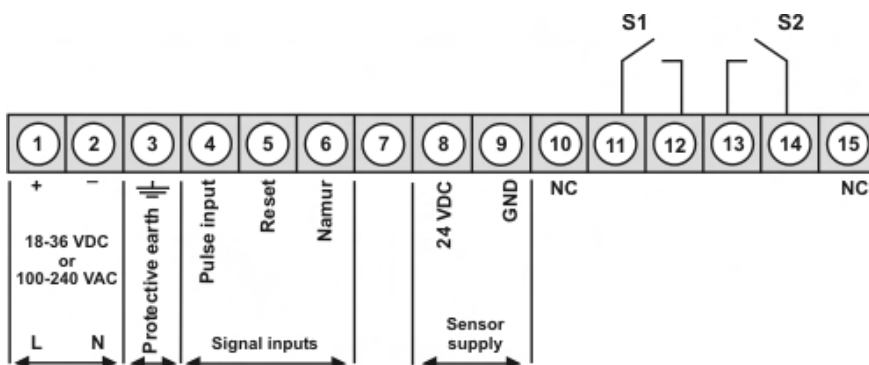

Electrical connection

4.3. Connection examples for **MG-AC**

Connection of a mechanical switch

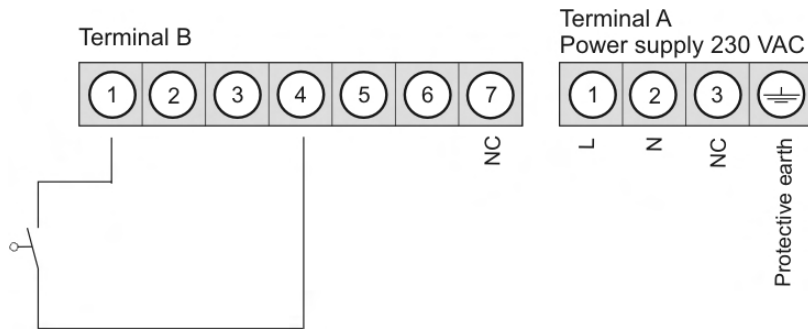

Connection of an initiator (npn) with external pull-up resistance

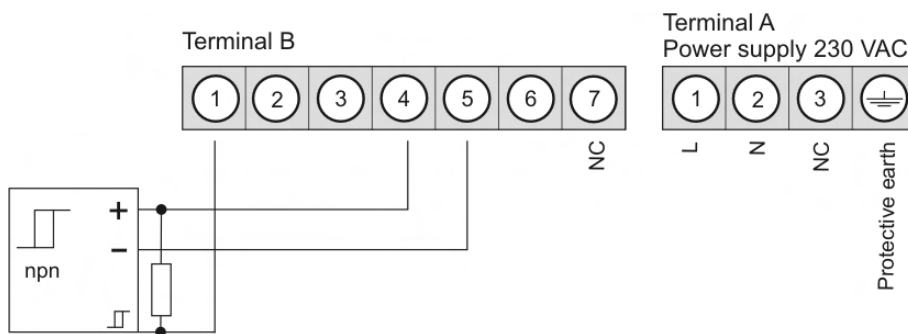

Connection of an initiator (pnp) with external pull-down resistance

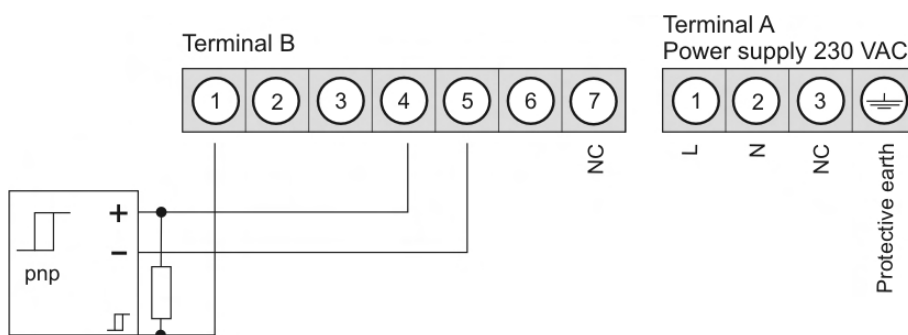

Connection of a namur sensor

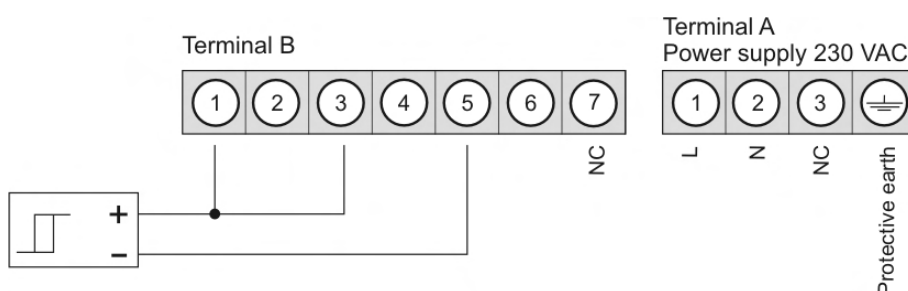

Operation

5. Operating and display elements

The devices are configured via 3 keys; depending on the size of the housing, the unit has a 4-...8-digit 7-segment display.

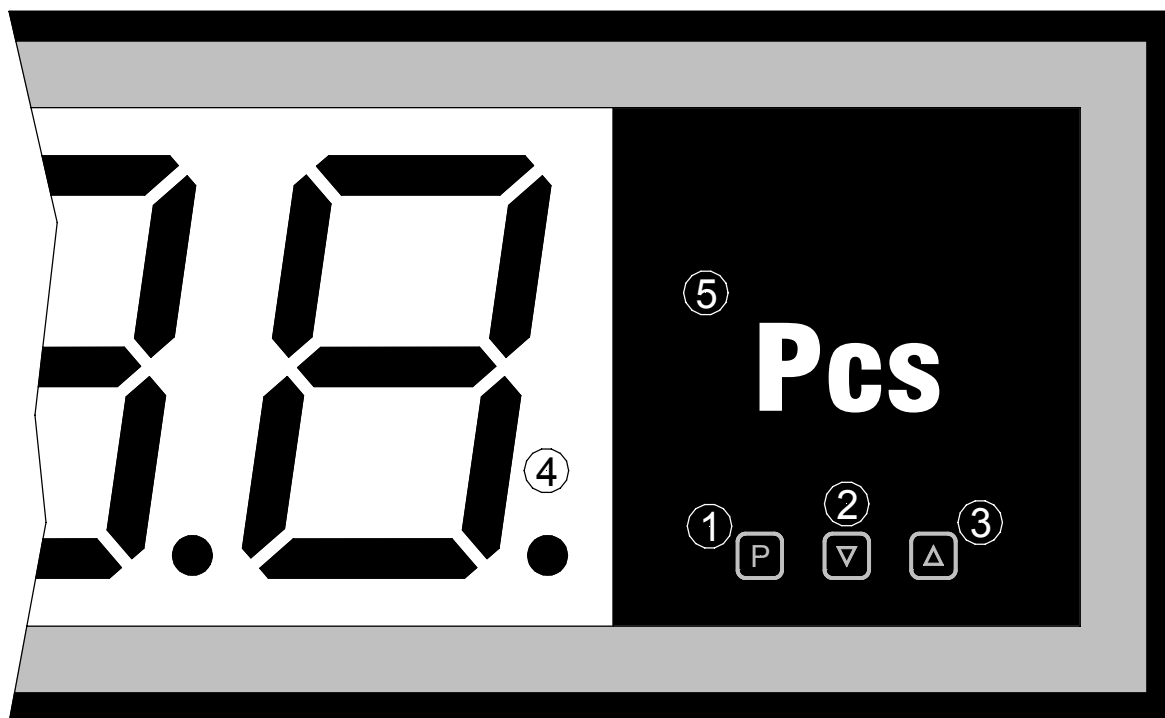

Operating and display elements

- | | |
|----------------------|--|
| 1 Program key
[P] | With the program key, you can call up the programming mode or perform various functions in the programming mode. |
| 2 Minus key
[▼] | The minus key is used exclusively in programming mode for setting parameters. |
| 3 Plus key
[▲] | The plus key is used in programming mode for setting parameters and also for resetting the counter. |
| 4 7-segment display | The 7-segment display shows either the count status during a counting process or the program numbers or parameters during programming. |
| 5 Dimension window | Here, a physical unit can be included in accordance with the customer's wishes |

Programming

6. Programming

This section deals with the programming and parameterisation of the **MG-XC**. It also describes the special features and effects of the individual parameters of the program numbers. The diagrams are always depicted here with 4 characters. The relevant keys are shown below the display, although they are positioned differently on the actual device. You can check the position and function of the keys in chapter 5.

In the display, the program numbers (PN) are shown, right-justified, as a 3-digit number with a **P** in front of them.

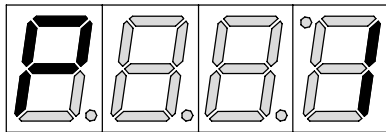

Display of e.g. program number 1

6.1. Programming procedure

The entire programming of the **MG-XC** is done by the steps described below.

Change to programming mode

Push the **[P]** key to change into programming mode. The unit goes to the lowest available program number. If the programming lock is activated, the key must be pushed for at least 1 second.

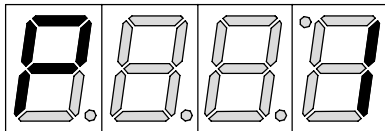

Example:

Change to programming mode by pushing key **[P]**. The first released program number (PN) appears, in this case PN1.

Change to other program numbers

To change between individual program numbers, hold the **[P]** key down and push the **[▲]** key for changing to a higher program number or the **[▼]** key for changing to a lower number. By keeping the keys pushed, e.g. **[P]** & **[▲]**, the display will begin, after approx. 1 second, to automatically run through the program numbers.

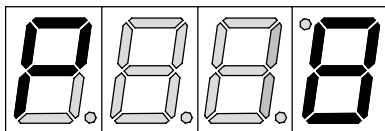

Example:

A 0 is parameterised under PN8.

Keep **[P]** key pushed and push the **[▲]** key several times. PN8 appears in the display. Under this parameter, the starting value of the counter can be set.

Change to the parameters set

Once the program number appears in the display, you can push the **[▼]** or **[▲]** key to get to the parameters set for this program number. The currently stored parameters are displayed.

Programming

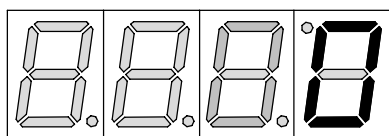

Example:

By pushing the [▼] or [▲] key, the currently stored value for PN8 appears in the display. In this case, it is 0.

Changing a parameter

After changing to the parameter, the lowest digit of the respective parameter flashes on the display. The value can be changed with the [▲] or [▼] key. To move to the next digit, the [P] key must be briefly pushed. Once the highest digit has been set and confirmed with [P], the lowest digit will begin to flash again.

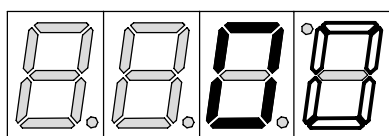

Example:

The 0 is flashing this is the lowest digit and asks if you want to change it. Let us assume the figure is to be changed from 0 to 60.

Briefly push the [P] key to move to the next digit.

The 0 begins to flash. Change the figure by pushing [▲] or [▼] to change the digit from 0 to 6. Briefly push the [P]

key to move on to the next digit. The 0 does not need to be changed. If the maximum value for the particular position has been reached, it will jump back to zero.

Saving parameters

All parameters must be acknowledged by the user by pushing the [P] key for one second. The changed parameters are then taken over as the current operating parameters and saved in the EEPROM.

This is confirmed by horizontal bars lighting up in the display.

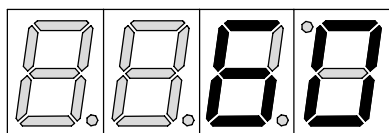

Example:

Save the parameters by pushing [P] for 1 second. All the newly entered data are confirmed by the unit. If no confirmation is received, the relevant parameters have not been saved.

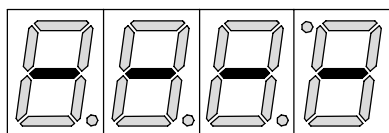

Example:

You receive confirmation from the unit that the changes have been saved through the appearance of horizontal bars in the middle segments.

Changing from programming to operating mode

If no key is pushed in the programming mode for about 7 seconds, the unit will return automatically to operating mode.

Software

7. Software

7.1. Range of functions

- ◆ One channel counter
- ◆ Operating hour counter via 10 ms-, 100 ms-, 1 s- time base
- ◆ Selectable slope (forward / backward)
- ◆ The count is saved cyclically and also in the event of a power failure
- ◆ Factorisation (multiplier / divisor / floating point)
- ◆ Forward / backward counting with definable start value
- ◆ 2 setpoints on display values
- ◆ Parametrizable drop-out delay after a breach of the limit value
- ◆ Frequency division via switch outputs
- ◆ Decimal point can be freely positioned
- ◆ Static or dynamic counter reset on keyboard stroke and / or reset input
- ◆ Adjustable reset source (keystroke, reset input, limit value)
- ◆ Debouncing for mechanical contacts (connectable 30 Hz-filter)
- ◆ Connectable basic divider for pulse recording (1/100 pulse divider)
- ◆ Programming lock
- ◆ Upper counter frequency limit 10 kHz
- ◆ Optionally 4...8 digits

7.2. Switching on

After switching on, a segment test "8.8.8.8" is carried out and then the name of the software version is displayed.

7.3. Help

On switching on, the content of the EEPROMS is checked on the basis of the stored test sum and, if there is an error, HELP is shown in the display. This error can only be overcome by making a reset to the factory parameters, for which the program key must be held down during start-up of the unit.

7.4. Overflow

For the counter to 'overflow' (forward counting), all segments with a "9" must be triggered, whereby the parameterised decimal point is retained. During an overflow, the display flashes. The error can be erased via a counter reset, which can be initiated by the parameterisable input or a configuration change.

7.5. Underflow

If a backward count is being made and the value on the counter falls below zero, all the display segments will flash with a "0". This is an underflow. It must be assumed that no negative values should occur. For the set points, however, a zero must be parameterisable as the switch limit value.

7.6. Forward / backward counter

The counter can be parameterised as a forward or backward counter. A starting value can also be defined. When counting forwards, the display value will go up by the increment parameterized under PN3/4, and when counting backwards, subtracted as the decrement.

Software

7.7. Pre-scaler function 1/1000

If program number 3 is programmed to "multiply by 1/1000", a floating point value can be added via the pulse number. The value relates to the digits in the display without any reference to the decimal point setting PN5. With this process, carry-overs can occur. When this happens, the display will always round them up. The calculated display value then also serves as the reference for the thresholds!

This function only has only has a limited amount of number space. This means that premature overflow can occur. The limit value (G) for the number of pulses can be derived from the following formula:

$$G = 2^{32 - \frac{\log(PN4)}{\log 2}}$$

Program table

8. Program table

The program table lists all the program numbers (PN) with their function, range of values, default values and user level.

PN	Description	Range of settings	Default
1	Polarity of the inputs (0 = rising / npn ; 1 = falling / pnp)	0 / 1	0
2	Mode of operation of the counter 0 = normal pulse counter without filter 1 = damping to 30 Hz 2 = 1/100 – pre-divider 3 = counter increment every 10 ms 4 = counter increment every 100 ms 5 = counter increment every 1 s	0 / 1 / 2 / 3 / 4 / 5	0
3	Pre-scaler function 0 = multiplying 1 = dividing 2 = 1/1000 multiplying (rounded)	0 / 1 / 2	0
4	Pre-scaler factor	1...32000 (9999)	1
5	Decimal point setting	000000...0.00000	none
6	Reset mode to starting value 0 = none; 1 = key reset ([▲]-key) 2 = input reset 3 = key or input reset 4 = reset via limit value 5 = limit value or key reset 6 = limit value or input reset 7 = all possible reset sources	0 / 1 / 2 / 3 / 4 / 5 / 6 / 7	3
7	Reset treatment 0 = static 1 = slope-triggered 2 = Debouncing (Push reset signal at least 0.5s)	0 / 1	0
8	Starting value of the counter (scaled)	0000...max.	0
9	Count direction of 0 = forward counter 1 = backward counter	0 / 1	0
10	Limit value for the counter reset	0000...max.	1000
50	Authorization code	0000...9999	0000
51	Preset authorization code	0000...9999	0000
60	Limit value function set point 1 0 = no limit value monitoring 1 = simple limit value monitoring 2 = cyclical limit value switch	0 / 1 / 2	0
61	Limit value threshold or cycle value (given as scaled value)	0000...max.	0
62	Drop-out time in ms (depending on mode of operation)	0...100	0
63	Mode of operation (0 = closed circuit; 1 = open circuit)	0 / 1	1

Program table

PN	Description	Range of settings	Default
70	Limit value function set point 2 0 = no limit value monitoring 1 = simple limit value monitoring 2 = cyclical limit value switching	0 / 1 / 2	0
71	Limit value threshold or cycle value (indicated as calculated value)	0000...max.	0
72	Drop-out time in ms (depending on mode of operation)	0...100	0
73	Mode of operation (0 = closed circuit; 1 = open circuit)	0 / 1	1

8.1. pnp/npn logics PN1

With this parameter, the slope is defined on which the device classifies a level as logical 1 at the inputs. This setting is valid globally for all inputs.

pnp: classifies a logical 1 for a switch from 0 \square 24 V

npn: classifies a logical 0 for a switch from 24 \square 0 V

8.2. Mode of operation of the counter PN2

The counter supports a number of operating modes. With PN2=0, a simple pulse count is made. The counter responds with its maximum reaction speed. When PN2=1 is chosen, an input filter of 30 Hz is put in place, i.e. frequencies above 30 Hz are not counted. This makes it possible to debounce mechanical contacts, because, in the bouncing phase, a higher frequency than 30 Hz occurs. Where PN2=2, a 1/100 pre-divider can be switched on. This divides the counting signal by 100 before processing. This must be taken into account in particular with pre-scaler function PM3/4! When PN2=3 is selected, the counter can be used as a time counter, moving on one place every 10 ms. This can be processed like a pulse counter value via PN3/4. The actual counting input serves as a gate element. Depending on the preset logics PN1, the counter is stopped on the counting input at a logical 1 (PN1=0) or logical 0 (PN1=1). Where PN2=4 or 5, only the time basis for the counter increment is changed.

8.3. Pre-scaler function PN3

This function is used to stipulate how the value set under PN4 is considered in the calculation of the displayed result. It can either be used as a multiplier, which results, for example, in 5 display units being added to the display for each pulse, or it can be used as a divisor, in which case, e.g. after every 5 pulses, the display moves on 1.

With the function "multiply by 1/1000", the set value is added on with each pulse. The result is always related to the last digit (units position) of the display, i.e. if PN4 is set at 20, the units position moves up one digit after 50 pulses. With scaling, the figure is always rounded up, so that, on counting forwards, the first pulse after the counter reset always triggers one display increment even if a 1 is programmed under PN4.

Program numbers

8.4. Pre-scaler factor PN4

The pre-scaler factor is a number with which every input pulse or time unit is weighted before being included in the displayed value. The range of settings is restricted 1...9999.

8.5. Decimal point PN5

The decimal point can be freely parameterised, depending on the number of digits in the display, from 0 to 7 places after the decimal point.

8.6. Reset mode PN6

With the reset mode, the parameter for the event that is to return the counter to the starting value can be entered. Possible sources are the reset input, the [▲]-key or the limit value PN10.

8.7. Reset treatment PN7

With this program number, the treatment of the reset signal is fixed. With a static evaluation, the counter is kept at 0 for the duration of the event. With an evaluation of the slope, the unit responds to the relevant slope change by returning the counter to 0 and the count is immediately continued. By debouncing, the reset signal needs to be pushed for at least 0.5s, so the counter value will change to the starting value.

8.8. Starting value PN8

Here, the value is defined at which the counter springs back in the case of a reset.

8.9. Counting direction PN9

The counting direction defines whether the counter counts up from the starting value (forward counter) or down (backward counter).

8.10. Limit value for counter reset PN10

Under this program number, the limit value is entered at which, with forward counting, the counter is set at the starting value on exceeding the respective limit value or, with backward counting, on falling below the given value. Parameterisation must also be carried out under PN6 or PN7.

8.11. Authorization code PN50

Here, the authorization code for programming is entered. The value of PN50 must correspond to the value of PN51.

8.12. Preset authorization code PN51

Here, the code must be entered that is needed under PN 50 to gain authorization for programming.

Program numbers

8.13. Limit value function of the set points PN60/70

The set points have 3 types of functions. Firstly, the set points can be deactivated via PN60/70=0. Secondly, with PN60/70=1, a simple limit value function can be performed in which the digital output is switched on or off when the limit value PN61/71 is exceeded (depending on the set mode of operation in PN63/73). Thirdly, with the cyclical limit value switching (PN60/70=2), the limit value is raised by the value set under PN61/71 when it is reached. This enables a pulse division to be attained.

8.14. Limit value threshold of the set points PN61/71

This indicates the threshold for the simple limit value monitoring (PN 60/70=1), which brings about a switching of the respective output. In the case of cyclical limit value switching (PN 60/70=2), when the current limit value is reached, it is raised by the threshold value set here. Because, as a result of this, the breaching of the limit value is annulled, the set point for the drop out time (PN62/72) is activated. If PN62/72 is set to 100, a pulse is emitted every time the display shows a value that can be divided exactly by 100, in other words, an output pulse is generated whenever the display shows 100, 200, 300...1300, 1400...

8.15. Drop out time of the set points PN62/72

The drop out time defines the earliest time that the breach of the limit value should be withdrawn. Should the breach of the limit value last longer than the drop out time given here, the output will be reset as soon as the value falls below the threshold value. With the open-circuit principle, it should be borne in mind that the output is switched off with a delay and, with the closed-circuit principle, switched on with a delay.

8.16. Mode of operation of the set points PN63/73

The mode of operation governs whether the output is switched on (open-circuit principle = operating current) or off (closed-circuit principle = idle current) when the limit value is exceeded.

Technical data

9. Technical data

Housing dimension

Construction

instrument

(without plug)

Version A

57 mm display

W 336 x H 144 x D 82 mm

100 mm display

W 550 x H 200 x D 82 mm

Version B

57 mm display

W 316 x H 124 x D 82 mm

100 mm display

W 526 x H 176 x D 82 mm

Fixing

With fixing brackets at the rear side

Material

Aluminium, black, powder-coated

Protection class

IP65

Weight

57 mm display

approx. 3.0 kg

100 mm display

approx. 5.0 kg

Connection

57/100 mm display

Type of plug:

Circular plug-in connector Binder-Series 693

Cable admission:

PG9 (6.0 to 9.5 mm)

Protection class:

IP65

Mechani life expectancy: > 500 contact durability

Connection type:

Screws

Connection

Voltage supply:

Number of poles:

3 + PE

Cable cross section:

0.5 to 2.5 mm (AWG 20...14)

Rating:

400 V

Rating current:

12 A

Connection

Inputs / Outputs:

Number of poles:

7

Cable cross section:

0.34 to 1.5 mm (AWG 22...16)

Rating:

250 V

Rating current:

8 A

Technical data

Housing dimension	Version A	
Panel meter (without plug terminal)	57 mm display 100 mm display	W 336 x H 144 x D 82 mm W 550 x H 200 x D 82 mm
	Version B	
	57 mm display 100 mm display	W 316 x H 124 x D 82 mm W 526 x H 176 x D 82 mm
(with plug terminal)	Version A / B	
	57 mm /100 mm display	W ... x H ... x D 104 mm
Assembly cut out	Version A	
	57 mm display 100 mm display	W 330.0 ^{-0.5} x H 138.0 ^{-0.5} mm W 544.0 ^{-0.5} x H 194.0 ^{-0.5} mm
	Version B	
	57 mm display 100 mm display	W 310.0 ^{-0.5} x H 90.0 ^{-0.5} mm W 520.0 ^{-0.5} x H 194.0 ^{-0.5} mm
	Weight	
	57 mm display 100 mm display	approx. 3.0 kg approx. 5.0 kg
	Connection	
	57/100 mm display	3-way adaptable screw terminal for voltage supply for line diameter by 2.5 mm ² 9-way adaptable screw terminal for voltage supply for line diameter by 1.5 mm ²
Display	Display	7-segment LED
	Digit height	57 mm, 100 mm
	Segment colour	red (optionally green)
	Number of digits	4 to 8 digits
Input	Pulse rate	10000 pulses/s max. 30 pulses/s with active damping
	Input resistance	approx. 10 kOhm
	Input voltage	±5...24 V
	HIGH- / LOW level	> 6 V / < 4 V
Output	Transmitter supply	24 VDC / 50mA
	Namur supply	1,5 mA
	Setpoints	30 VAC / 0.4 A – 30 VDC / 0.4 A
	Photo Mos	Input/output dielectric strength 100 VAC
Power supply		
Supply voltage	100-240 VAC 50/60 Hz, DC +/-10 % 18-36 VDC (galv. insulated)	
Power consumption	max. 30 VA	

Memory	Parameter memory EEPROM
Data life	>30 years
Ambient conditions	
Working temperature	0...60 °C
Storage temperature	-20...80 °C
Climatic resistance	rel. ≤ 75 % on year average without dew
EMV	DIN 61326
CE-sign	Conformity to 89/336/EWG
Safety standard	DIN 61010

Memos

10. Memos